

County estimates of average dollar value per acre for Iowa farmland based on U.S. Census of Agriculture estimates and a Nov. 1, 1996, survey of Iowa real estate brokers. The top figure is the estimated Nov. 1, 1996, value; the bottom figure is the percentage of increase over the estimated Nov. 1, 1995, value.

LYON	OSCEOLA	DICKINSON	EMMET	KOSSUTH	WINNEBAGO	WORTH	MITCHELL	HOWARD	WINNEBAGO	ALLAMAKEE
1827	2005	1836	2122	2213	1905	1854	1683	1316	1298	968
1565	1717	1573	1819	1899	1632	1584	1434	1134	1131	854
SIoux	O'BRIEN	CLAY	PALO ALTO		HANCOCK	CERRO GORDO	FLOYD	CHICKASAW	FAYETTE	CLAYTON
2050	2303	2020	2042		2086	2001	1769	1476	1623	1282
1766	1973	1732	1752		1787	1709	1507	1272	1414	1131
PLYMOUTH	CHEROKEE	BUENA VISTA	POCAHONTAS	HUMBOLDT	WRIGHT	FRANKLIN	BUTLER	BREMER	DELAWARE	DUBUQUE
1888	1863	2171	2224	2294	2380	2092	1943	1814	1869	1624
1638	1606	1861	1893	1940	2014	1784	1646	1562	1630	1428
WOODBURY	IDA	SAC	CALHOUN	WEBSTER	HAMILTON	HARDIN	GRUNDY	BLACK HAWK	BUCHANAN	JONES
1517	1855	2035	2258	2379	2429	2203	2294	2128	1840	1449
1324	1609	1738	1881	1983	2026	1838	1905	1792	1576	1260
MONONA	CRAWFORD	CARROLL	GREENE	BOONE	STORY	MARSHALL	TAMA	BENTON	LINN	JACKSON
1371	1656	1950	1964	2260	2329	1906	1833	2023	2136	1644
1198	1435	1665	1639	1858	1928	1623	1549	1693	1834	1416
HARRISON	SHELBY	AUDUBON	GUTHRIE	DALLAS	POLK	JASPER	POWESHIEK	IOWA	JOHNSON	CLINTON
1427	1546	1647	1516	1816	1916	1726	1674	1674	2059	1739
1265	1369	1441	1306	1523	1612	1536	1483	1475	1849	1495
POTTAWATTAMIE	CASS	ADAIR	MADISON	WARREN	MARION	MAHASKA	KEOKUK	WASHINGTON	MUSCATINE	SCOTT
1490	1406	1046	1257	1370	1354	1457	1439	1882	2007	2735
1339	1260	937	1113	1175	1200	1324	1329	1737	1755	2332
MILLS	MONTGOMERY	ADAMS	UNION	CLARKE	LUCAS	MONROE	WAPELLO	JEFFERSON	HENRY	LOUISA
1431	1259	1070	955	830	764	920	1081	1189	1545	1642
1302	1146	957	840	723	658	821	983	1080	1605	DES MOINES
FREMONT	PAGE	TAYLOR	RINGGOLD	DECATUR	WAYNE	APPANOOSE	DAVIS	VAN BUREN	1404	1458
1361	1120	901	786	677	751	714	915	1027	LEE	
1239	1020	806	692	583	646	615	814	915	1376	
									1222	

County estimates of average dollar value per acre for Iowa farmland based on U.S. Census of Agriculture estimates and a Nov. 1, 1996, survey of Iowa real estate brokers. The top figure is the estimated Nov. 1, 1996, value; the bottom figure is the estimated Nov. 1, 1995, value.

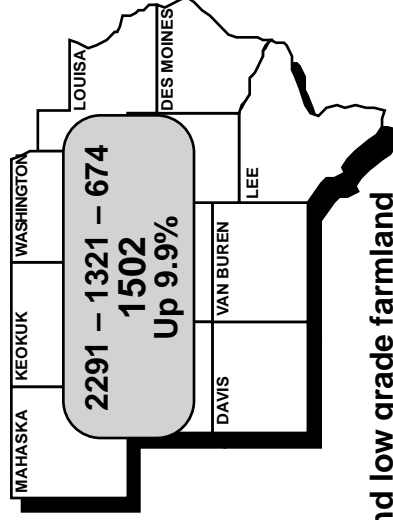
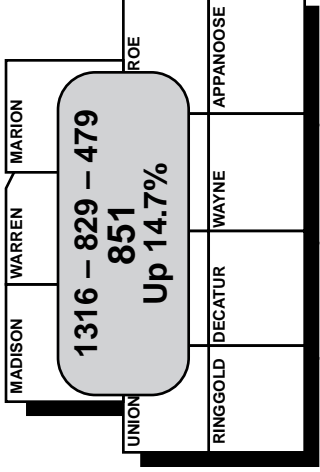
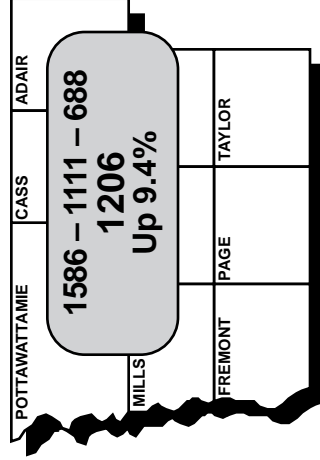
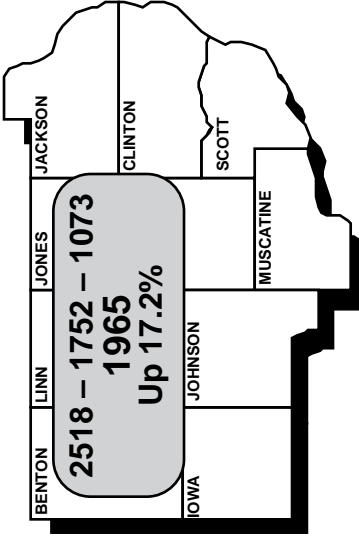
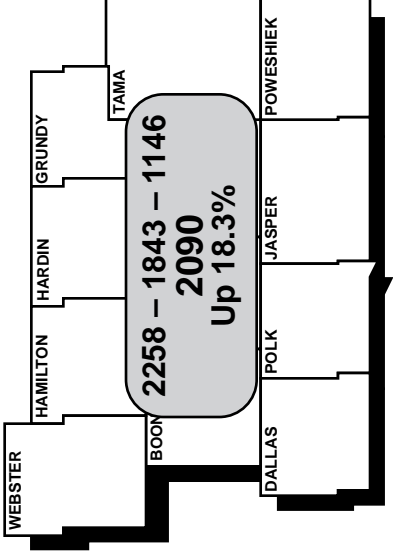
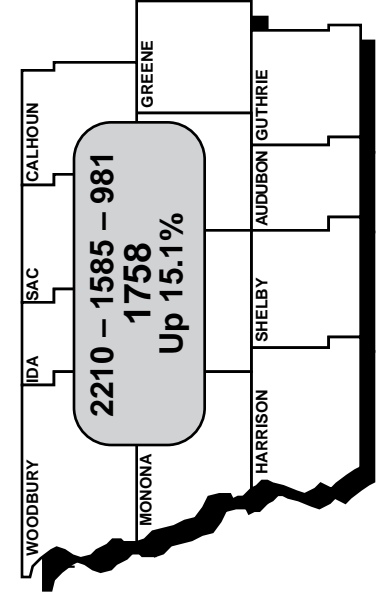
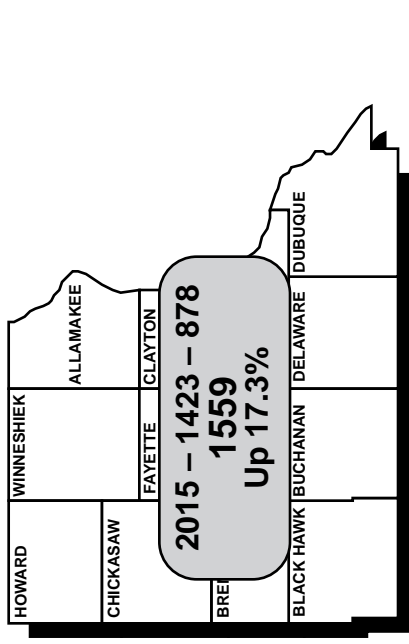
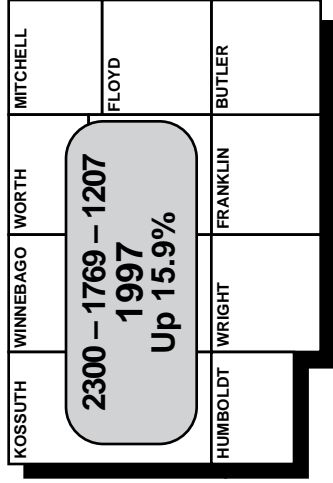
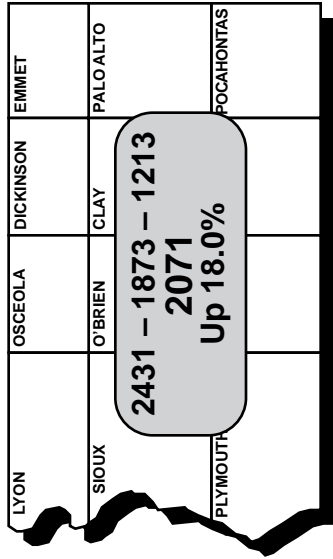

Estimates of average dollar value per acre for high, medium and low grade farmland on Nov. 1, 1996, by Iowa Crop Reporting District; and the Crop Reporting District average and the average percentage change from Nov. 1, 1995. The estimates are based on a survey of Iowa real estate brokers.

Comparative Iowa Land Values

1995-1996

By Crop Reporting District:

District	1996 \$/acre	1995 \$/acre	1995-96 Change		County Name	1996 \$/acre	1995 \$/acre	1995-1996	
			\$	%				\$ Change	% Change
Northwest	2071	1755	316	18.0%	Hancock	2086	1787	299	16.7%
North Central	1997	1724	273	15.9%	Hardin	2203	1838	365	19.9%
Northeast	1559	1330	229	17.3%	Harrison	1427	1265	164	13.0%
West Central	1758	1528	230	15.1%	Henry	1545	1404	141	10.0%
Central	2090	1766	324	18.3%	Howard	1316	1134	182	16.0%
East Central	1965	1676	289	17.2%	Humboldt	2294	1940	354	18.2%
Southwest	1206	1102	104	9.4%	Ida	1855	1609	246	15.3%
South Central	851	742	109	14.7%	Iowa	1674	1475	199	13.5%
Southeast	1502	1367	135	9.9%	Jackson	1449	1260	189	15.0%
State Avg.	1682	1455	227	15.6%	Jasper	1726	1536	190	12.4%
					Jefferson	1189	1080	109	10.1%
					Johnson	2059	1849	210	11.4%
					Jones	1644	1416	228	16.1%
					Keokuk	1439	1329	110	8.3%
					Kossuth	2213	1899	314	16.5%
					Lee	1376	1222	154	12.6%
					Linn	2136	1834	302	16.5%
					Louisa	1831	1642	189	11.5%
					Lucas	764	658	106	16.1%
					Lyon	1827	1565	262	16.7%
					Madison	1257	1113	144	12.9%
					Mahaska	1457	1324	133	10.0%
					Marion	1354	1200	154	12.8%
					Marshall	1906	1623	283	17.4%
					Mills	1431	1302	129	9.9%
					Mitchell	1683	1434	249	17.4%
					Monona	1371	1198	173	14.4%
					Monroe	920	821	99	12.1%
					Montgomery	1259	1146	113	9.9%
					Muscatine	2007	1755	252	14.4%
					O'Brien	2303	1973	330	16.7%
					Osceola	2005	1717	288	16.8%
					Page	1120	1020	100	9.8%
					Palo Alto	2042	1752	290	16.6%
					Plymouth	1888	1638	250	15.3%
					Pocahontas	2224	1893	331	17.5%
					Polk	1916	1612	304	18.9%
					Pottawattamie	1490	1339	151	11.3%
					Poweshiek	1674	1483	191	12.9%
					Ringgold	786	692	94	13.6%
					Sac	2035	1738	297	17.1%
					Scott	2735	2332	403	17.3%
					Shelby	1546	1369	177	12.9%
					Sioux	2050	1766	284	16.1%
					Story	2329	1928	401	20.8%
					Tama	1833	1549	284	18.3%
					Taylor	901	806	95	11.8%
					Union	955	840	115	13.7%
					Van Buren	1027	915	112	12.2%
					Wapello	1081	983	98	10.0%
					Warren	1370	1175	195	16.6%
					Washington	1882	1737	145	8.3%
					Wayne	751	646	105	16.3%
					Webster	2379	1983	396	20.0%
					Winnebago	1905	1632	273	16.7%
					Winneshiek	1298	1131	167	14.8%
					Woodbury	1517	1324	193	14.6%
					Worth	1854	1584	270	17.0%
					Wright	2380	2014	366	18.2%

By County:

County Name	1996 \$/acre	1995 \$/acre	1995-1996	
			\$ Change	% Change
Adair	1046	937	109	11.6%
Adams	1070	957	113	11.8%
Allamakee	968	854	114	13.3%
Appanoose	714	615	99	16.1%
Audubon	1647	1441	206	14.3%
Benton	2023	1693	330	19.5%
Black Hawk	2128	1792	336	18.8%
Boone	2260	1858	402	21.6%
Bremer	1814	1562	252	16.1%
Buchanan	1840	1576	264	16.8%
Buena Vista	2171	1861	310	16.7%
Butler	1943	1646	297	18.0%
Calhoun	2258	1881	377	20.0%
Carroll	1950	1665	285	17.1%
Cass	1406	1260	146	11.6%
Cedar	2196	1906	290	15.2%
Cerro Gordo	2001	1709	292	17.1%
Cherokee	1863	1606	257	16.0%
Chickasaw	1476	1272	204	16.0%
Clarke	830	723	107	14.8%
Clay	2020	1732	288	16.6%
Clayton	1282	1131	151	13.4%
Clinton	1739	1495	244	16.3%
Crawford	1656	1435	221	15.4%
Dallas	1816	1523	293	19.2%
Davis	915	814	101	12.4%
Decatur	677	583	94	16.1%
Delaware	1869	1630	239	14.7%
Des Moines	1605	1458	147	10.1%
Dickinson	1836	1573	263	16.7%
Dubuque	1624	1428	196	13.7%
Emmet	2122	1819	303	16.7%
Fayette	1623	1414	209	14.8%
Floyd	1769	1507	262	17.4%
Franklin	2092	1784	308	17.3%
Fremont	1361	1239	122	9.8%
Greene	1964	1639	325	19.8%
Grundy	2294	1905	389	20.4%
Guthrie	1516	1306	210	16.1%
Hamilton	2429	2026	403	19.9%